

Accurate Electrical Battery Model Capable of Predicting Runtime and I - V Performance

Min Chen, *Student Member, IEEE*, and Gabriel A. Rincón-Mora, *Senior Member, IEEE*

Abstract—Low power dissipation and maximum battery runtime are crucial in portable electronics. With accurate and efficient circuit and battery models in hand, circuit designers can predict and optimize battery runtime and circuit performance. In this paper, an accurate, intuitive, and comprehensive electrical battery model is proposed and implemented in a Cadence environment. This model accounts for all dynamic characteristics of the battery, from nonlinear open-circuit voltage, current-, temperature-, cycle number-, and storage time-dependent capacity to transient response. A simplified model neglecting the effects of self-discharge, cycle number, and temperature, which are nonconsequential in low-power Li-ion-supplied applications, is validated with experimental data on NiMH and polymer Li-ion batteries. Less than 0.4% runtime error and 30-mV maximum error voltage show that the proposed model predicts both the battery runtime and I - V performance accurately. The model can also be easily extended to other battery and power sourcing technologies.

Index Terms—Batteries, cadence simulation, electrical model, I - V performance, nickel-metal hydride battery, polymer lithium-ion battery, runtime prediction, test system.

I. INTRODUCTION

ELECTROCHEMICAL batteries [1] are of great importance in many electrical systems because the chemical energy stored inside them can be converted into electrical energy and delivered to electrical systems, whenever and wherever energy is needed. Although the popularity of portable electronics like cell phones, PDAs, digital cameras, and laptop computers has propelled battery technologies, such as nickel cadmium (NiCd), nickel-metal hydride (NiMH), lithium-ion (Li-ion), and polymer Li-ion [2], those battery technologies cannot yet meet the progressive energy demands and size limitations of today's portable electronics [3].

A primary concern in the design of portable electronics is how to minimize power dissipation and extend battery runtime [4]. Without circuit and battery models in hand, circuit designers can neither predict nor optimize either battery runtime or circuit performance. Although accurate and efficient electrical models of circuits and systems at different levels of abstraction have been developed and also have been implemented in some electronic design automation (EDA) tools, like in Cadence design systems, an accurate, intuitive, and comprehensive electrical battery model is not available, especially in circuit simulators,

because of the complicated physical and dynamic properties of batteries [1].

A battery model capable of predicting both the runtime and I - V performance can be used to design energy-aware circuits and systems [5], optimize circuit and system performance [6], [7], predict battery runtime for different load profiles [8], emulate batteries with electronic circuits [9], and improve battery energy efficiency [10]. The proposed model predicts all the important properties and is compatible with lead-acid, NiCd, NiMH, Li-ion, polymer Li-ion, and other electrochemical batteries. More importantly, its ability to be conveniently simulated with other circuits and systems in Cadence-compatible simulators allows for optimum system designs and simulations. With minor modifications, this model can be extended to fuel cells and other power sources.

This paper is organized as follows. Section II reviews state of the art in battery models. Section III introduces the proposed model and explains the significance of the various model parameters. Section IV describes a battery test system and an experimental procedure used to extract the various model parameters. Finally, Section V presents the extracted model parameters, Section VI validates the proposed model by comparing simulation results with experimental data, and Section VII concludes the paper.

II. BACKGROUND

Researchers around the world have developed a wide variety of models with varying degrees of complexity. They capture battery behavior for specific purposes, from battery design and performance estimation to circuit simulation. Electrochemical models [11]–[14], mainly used to optimize the physical design aspects of batteries, characterize the fundamental mechanisms of power generation and relate battery design parameters with macroscopic (e.g., battery voltage and current) and microscopic (e.g., concentration distribution) information. However, they are complex and time consuming because they involve a system of coupled time-variant spatial partial differential equations [13]—a solution for which requires days of simulation time, complex numerical algorithms, and battery-specific information that is difficult to obtain, because of the proprietary nature of the technology.

Mathematical models [8], [10], [15]–[18], mostly too abstract to embody any practical meaning but still useful to system designers, adopt empirical equations or mathematical methods like stochastic approaches [10] to predict system-level behavior, such as battery runtime, efficiency, or capacity. However, mathematical models cannot offer any I - V information that is important to circuit simulation and optimization. In addition,

Manuscript received March 21, 2005; revised May 15, 2005. This work was supported by the Southeastern Center for Electrical Engineering Education (SCEEE) development fund grants. Paper no. TEC-00114-2005.

The authors are with the School of Electrical and Computer Engineering, Georgia Institute of Technology, Atlanta, GA 30332 USA (e-mail: minchen@ece.gatech.edu; rincon-mora@ece.gatech.edu).

Digital Object Identifier 10.1109/TEC.2006.874229

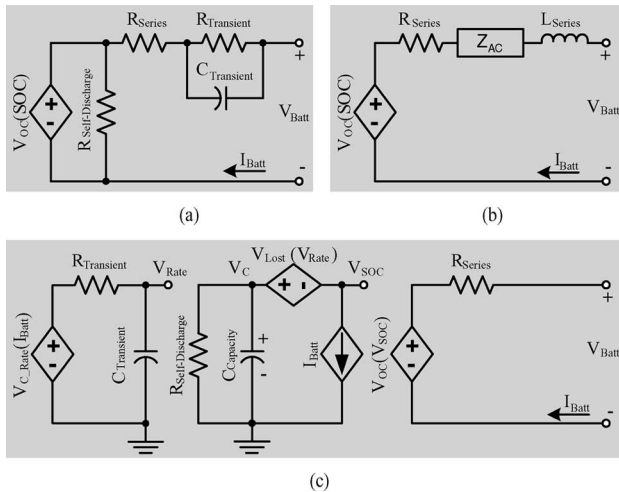

Fig. 1. State of the art. (a) Thevenin-, (b) impedance-, and (c) runtime-based electrical battery models.

most mathematical models only work for specific applications and provide inaccurate results in the order of 5%–20% error. For example, the maximum error of Peukert’s law predicting runtime can be more than 100% for time-variant loads [16].

Electrical models [4], [19]–[30], accuracy of which lies between electrochemical and mathematical models (around 1%–5% error), are electrical equivalent models using a combination of voltage sources, resistors, and capacitors for co-design and cosimulation with other electrical circuits and systems. For electrical engineers, electrical models are more intuitive, useful, and easy to handle, especially when they can be used in circuit simulators and alongside application circuits. There have been many electrical models of batteries, from lead-acid to polymer Li-ion batteries. Most of these electrical models fall under three basic categories: Thevenin- [19]–[25], impedance- [26], [27], and runtime-based models [4], [28], [29], as shown in Fig. 1.

A. Thevenin-Based Electrical Model

In its most basic form, a Thevenin-based model, shown in Fig. 1(a), uses a series resistor (R_{Series}) and an RC parallel network ($R_{Transient}$ and $C_{Transient}$) to predict battery response to transient load events at a particular state of charge (SOC), by assuming the open-circuit voltage [$V_{OC}(SOC)$] is constant. Unfortunately, this assumption prevents it from capturing steady-state battery voltage variations (i.e., dc response) as well as runtime information.

Its derivative models [19]–[25] gain improvements by adding additional components to predict runtime and dc response, but they still have several disadvantages. For example, [19] uses a variable capacitor instead of $V_{OC}(SOC)$ to represent nonlinear open-circuit voltage and SOC, which complicates the capacitor parameter, needs the integral over voltage to obtain SOC, and gives roughly 5% runtime error and 0.4-V error voltage for constant charge and discharge currents; [20] models the nonlinear relation between the open-circuit voltage and SOC, but ignores the transient behavior; [21], [22] and [24] need additional mathematical equations to obtain the SOC and estimate

TABLE I
COMPARISON OF VARIOUS CIRCUIT MODELS

PREDICTING CAPABILITY	THEVENIN-BASED MODEL	IMPEDANCE-BASED MODEL	RUNTIME-BASED MODEL
DC	NO	NO	YES
AC	LIMITED	YES	NO
TRANSIENT	YES	LIMITED	LIMITED
BATTERY RUNTIME	NO	NO	YES

runtime, and they are not implemented in circuit simulators; [23] adopts two constant RC parallel networks, but only works at a particular SOC and temperature condition; [25] employs a complicated electrical network extracted from physical process to model open-circuit voltage (V_{OC}), which complicates the whole model. Thus, none of these Thevenin-based models can predict the battery runtime simply and accurately in circuit simulators.

B. Impedance-Based Electrical Model

Impedance-based models, shown in Fig. 1(b), employ the method of electrochemical impedance spectroscopy to obtain an ac-equivalent impedance model in the frequency domain, and then use a complicated equivalent network (Z_{ac}) to fit the impedance spectra. The fitting process is difficult, complex, and nonintuitive. In addition, impedance-based models only work for a fixed SOC and temperature setting [26], and therefore they cannot predict dc response or battery runtime.

C. Runtime-Based Electrical Model

Runtime-based models, shown in Fig. 1(c), use a complex circuit network to simulate battery runtime and dc voltage response for a constant discharge current in SPICE-compatible simulators. [28] and [29] are continuous-time implementations in SPICE simulators and [4] is a discrete-time implementation using Very high speed integrated circuit Hardware Description Language (VHDL) code. They can predict neither runtime nor voltage response for varying load currents accurately.

A brief comparison illustrated in Table I indicates that none of these models can be implemented in circuit simulators to predict both the battery runtime and I - V performance accurately. Therefore, a comprehensive battery model combining the transient capabilities of Thevenin-based models, ac features of impedance-based models, and runtime information of runtime-based models is highly desired for system design, integration, and optimization.

III. PROPOSED MODEL

An accurate, intuitive, and comprehensive electrical battery model is proposed in Fig. 2. On the left, a capacitor ($C_{Capacity}$) and a current-controlled current source, inherited from runtime-based models, model the capacity, SOC, and runtime of the battery. The RC network, similar to that in Thevenin-based models, simulates the transient response. To bridge SOC to open-circuit voltage, a voltage-controlled voltage source is used. The proposed model is a blend of previous models whose unique combination of components and dependencies eases the extraction

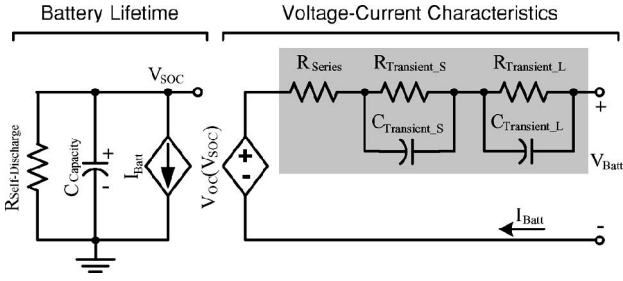

Fig. 2. Proposed electrical battery model.

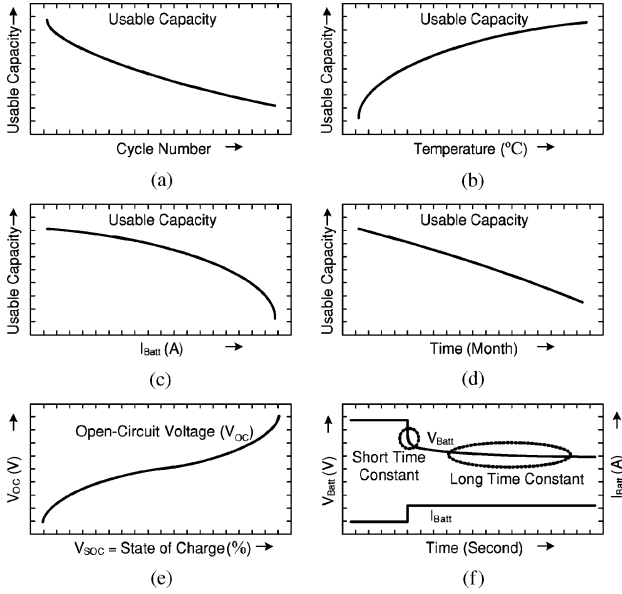

Fig. 3. Typical battery characteristic curves of usable capacity versus (a) cycle number, (b) temperature, (c) current, and (d) storage time, as well as (e) open-circuit voltage versus SOC and (f) transient response to a step load-current event.

procedure, makes a fully Cadence-compatible model possible, and simultaneously predicts runtime, steady state, and transient response accurately and “on the fly,” capturing all the dynamic electrical characteristics of batteries: usable capacity (C_{Capacity}), open-circuit voltage (V_{OC}), and transient response (RC network).

A. Usable Capacity

Assuming a battery is discharged from an equally charged state to the same end-of-discharge voltage, the extracted energy, called usable capacity, declines as cycle number, discharge current, and/or storage time (self-discharge) increases, and/or as temperature decreases, as shown in Fig. 3(a)–(d). The phenomenon of the usable capacity can be modeled by a full-capacity capacitor (C_{Capacity}), a self-discharge resistor ($R_{\text{Self-Discharge}}$), and an equivalent series resistor (the sum of R_{Series} , $R_{\text{Transient}_S}$, and $R_{\text{Transient}_L}$).

Full-capacity capacitor C_{Capacity} represents the whole charge stored in the battery, i.e., SOC, by converting nominal battery capacity in Ahr to charge in coulomb and its value is defined as

$$C_{\text{Capacity}} = 3600 \cdot \text{Capacity} \cdot f_1(\text{Cycle}) \cdot f_2(\text{Temp}) \quad (1)$$

where Capacity is the nominal capacity in Ahr and f_1 (Cycle) and f_2 (Temp) are cycle number- and temperature-dependent correction factors, shown in Fig. 3(a) and (b). By setting the initial voltage across C_{Capacity} (V_{SOC}) equal to 1 V or 0 V, the battery is initialized to its fully charged (i.e., SOC is 100%) or fully discharged (i.e., SOC is 0%) states. In other words, V_{SOC} represents the SOC of the battery quantitatively.

As seen from (1), C_{Capacity} will not change with current variation, which is reasonable for the battery’s full capacity because energy is conserved. The variation of current-dependent usable capacity, shown in Fig. 3(c), comes from different SOC values at the end of discharge for different currents owing to different voltage drops across internal resistor (the sum of R_{Series} , $R_{\text{Transient}_S}$, and $R_{\text{Transient}_L}$) and the same end-of-discharge voltage. When the battery is being charged or discharged, current-controlled current source I_{Batt} is used to charge or discharge C_{Capacity} so that the SOC, represented by V_{SOC} , will change dynamically. Therefore, the battery runtime is obtained when battery voltage reaches the end-of-discharge voltage.

Self-discharge resistor $R_{\text{Self-Discharge}}$ is used to characterize the self-discharge energy loss when batteries are stored for a long time. Theoretically, $R_{\text{Self-Discharge}}$ is a function of SOC, temperature, and, frequently, cycle number. Practically, it can be simplified as a large resistor, or even ignored, according to the capacity retention curve shown in Fig. 3(d), which shows that usable capacity decreases slowly with time when no load is connected to the battery.

B. Open-Circuit Voltage

Open-circuit voltage (V_{OC}) is changed to different capacity levels, i.e., SOC, as shown in Fig. 3(e). The nonlinear relation between the open-circuit voltage (V_{OC}) and SOC is important to be included in the model. Thus, voltage-controlled voltage source $V_{\text{OC}}(V_{\text{SOC}})$ is used to represent this relation. The open-circuit voltage is normally measured as the steady-state open-circuit terminal voltage at various SOC points. However, for each SOC point, this measurement can take days [30]. [30] offers two quick techniques, namely, extrapolation and averaging techniques, to ascertain the true open-circuit voltage (V_{OC}).

C. Transient Response

In a step load current event, the battery voltage responds slowly, as shown in Fig. 3(f). Its response curve usually includes instantaneous and curve-dependant voltage drops. Therefore, the transient response is characterized by the shaded RC network in Fig. 2. The electrical network consists of series resistor R_{Series} and two RC parallel networks composed of $R_{\text{Transient}_S}$, $C_{\text{Transient}_S}$, $R_{\text{Transient}_L}$, and $C_{\text{Transient}_L}$.

Series resistor R_{Series} is responsible for the instantaneous voltage drop of the step response. $R_{\text{Transient}_S}$, $C_{\text{Transient}_S}$, $R_{\text{Transient}_L}$, and $C_{\text{Transient}_L}$ are responsible for short- and long-time constants of the step response, shown by the two dotted circles in Fig. 3(f). On the basis of numerous experimental curves, using two RC time constants, instead of one or three, is the best tradeoff between accuracy and complexity because

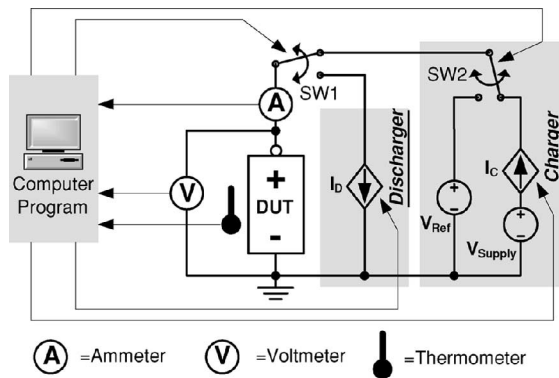

Fig. 4. Battery test system.

two RC time constants keep errors to within 1 mV for all the curve fittings. The detailed extraction methods can be found in [23].

Theoretically, all the parameters in the proposed model are multivariable functions of SOC, current, temperature, and cycle number. However, within certain error tolerance, some parameters can be simplified to be independent or linear functions of some variables for specific batteries. For example, a low-capacity battery in a constant-temperature application can ignore temperature effects, and a frequently used battery can ignore 5% per month self-discharge rate without suffering any significant errors.

IV. TEST SYSTEM AND PROCEDURE

To extract all the parameters in the proposed model, a battery test system and an experimental procedure were designed to measure batteries conveniently and efficiently. As shown in Fig. 4, the battery test system, implemented on a printed-circuit board (PCB) prototype, includes a charge circuit, a discharge circuit, and a computer program. A single-pole double-throw (SPDT) switch SW1 is used to switch between the charge and discharge circuits. In the charge circuit, another SPDT switch SW2 is used to switch between computer-controlled current I_C and constant voltage V_{Ref} to implement constant current charge for NiCd and NiMH batteries, or constant current-constant voltage charge for lead-acid, Li-ion, and polymer Li-ion batteries. In the discharge circuit, another computer-controlled current I_D is used to discharge batteries. Different end-of-charge and end-of-discharge rules are implemented in the computer program for various batteries. At the same time, the computer program monitors battery temperature and samples battery voltage and current once per second to obtain charge and discharge curves. Therefore, the battery test system can be used to test various batteries for model extraction.

The experimental procedure is similar to that in [30]. The major objective of the experimental procedure is to conveniently obtain the experimental curves of Fig. 3, thereby extracting all the parameters in the proposed model. The curves in Fig. 3(a), (b), and (d) are obtained by discharging the battery at various cycle numbers, temperatures, and after different storage time, respectively. The curves in Fig. 3(c), (e), and (f) are obtained by

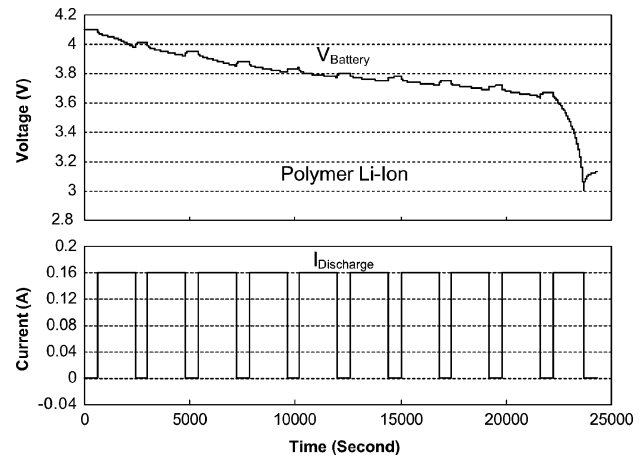

Fig. 5. Typical voltage response curve with pulse discharge current.

pulse discharging the battery with currents from 0.1 to 1 C [1] (C means the discharge current that discharges the nominal battery capacity in 1 h). Fig. 5 shows a typical discharge curve with 160-mA pulse current on a polymer Li-ion battery. The pulsewidth is chosen to guarantee enough “humps” (6–10) for sufficient data points and the off time is selected to allow the battery voltage to reach steady-state conditions (10 min in this case). Finally, all the model parameters are extracted from these experimental curves.

V. MODEL EXTRACTION

To validate the proposed model, the model parameters of a specific battery must be identified experimentally first. NiMH and polymer Li-ion batteries are chosen for model validation because they are widely popular in portable electronics today. For clarity, only polymer Li-ion batteries are discussed in the text, and the model extraction results of NiMH batteries are listed in the Appendix.

As mentioned in Section III, all the parameters in the proposed model are multivariable functions of SOC, current, temperature, and cycle number. These functions make the model extraction (i.e., the fitting of multivariable functions or multidimensional lookup tables) complex and the test process (i.e., hundreds of cycle measurements at various temperatures) long. Therefore, some subordinate parameters are simplified or ignored not only because it eases validation but also because they have negligible effects in polymer Li-ion batteries, like usable capacity dependence on self-discharge (2%–10% per month) and cycle number (less than 10% capacity loss over 300 cycles) [1]; therefore, $R_{Self-Discharge}$ is set to infinity and f_1 (Cycle) is set to one. Also, the usable capacity dependence on temperature is minimized for ease because our low-power application incurs little temperature fluctuations. Experimentally and only for the purposes of extracting parameters, a cooling fan was used to keep the battery temperature constant so that all the parameters are independent of temperature, i.e., f_2 (Temp) is set to one.

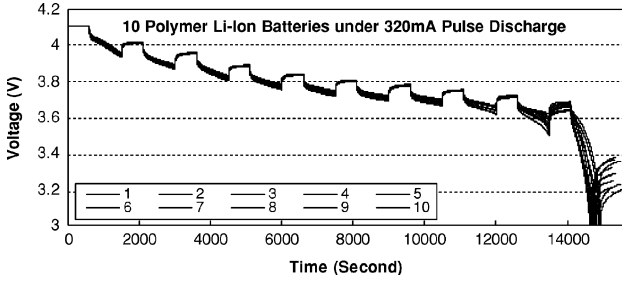

Fig. 6. A 320-mA pulse discharge curves of ten polymer Li-ion batteries.

A. Polymer Li-Ion Batteries

Ten new 850-mAh TCL PL-383562 polymer Li-ion batteries were tested with suitably-spaced pulse discharge currents (80, 160, 320, and 640 mA in this case) at room temperature. For safety consideration, these batteries were charged with constant currents less than 800 mA, 4.1-V constant voltage, and 10-mA end-of-charge current, and discharged with pulse currents aforementioned and 3.0-V end-of-discharge voltage. Their pulse discharge curves under the same conditions (i.e., the same current, temperature, and cycle number) stay very close to each other. As shown in Fig. 6, (320-mA pulse discharge curves) ten batteries show runtime variation within 2% and error voltage less than 30 mV at 10%–100% SOC. A big error voltage close to fully discharged states (0%–10% SOC) is caused by the sharp open-circuit voltage drop that influences battery runtime little. Because of their consistent characteristics, only one polymer Li-ion battery needs to be measured, and its model can be applied to other parts from the same manufacturer.

B. Model Extraction

One polymer Li-ion battery whose curves sit in the middle of those of other nine batteries was chosen to extract all the parameters in the proposed model. The full-capacity capacitor C_{Capacity} is set to 3060 F according to (1). Fig. 7 shows the extracted nonlinear open-circuit voltage $[V_{\text{OC}}(V_{\text{SOC}})]$, series resistor (R_{Series}), and RC network ($R_{\text{Transient}_S}$, $C_{\text{Transient}_S}$, $R_{\text{Transient}_L}$, and $C_{\text{Transient}_L}$) as functions of SOC and discharge current. All the extracted RC parameters are approximately constant over 20%–100% SOC and change exponentially within 0%–20% SOC caused by the electrochemical reaction inside the battery. Small parameter differences among the curves for different discharge currents indicate that these parameters are approximately independent of discharge currents, which can simplify the model. Single-variable functions were used to represent these curves, as shown by

$$V_{\text{OC}}(\text{SOC}) = -1.031 \cdot e^{-35 \cdot \text{SOC}} + 3.685 + 0.2156 \cdot \text{SOC} - 0.1178 \cdot \text{SOC}^2 + 0.3201 \cdot \text{SOC}^3 \quad (2)$$

$$R_{\text{Series}}(\text{SOC}) = 0.1562 \cdot e^{-24.37 \cdot \text{SOC}} + 0.07446 \quad (3)$$

$$R_{\text{Transient}_S}(\text{SOC}) = 0.3208 \cdot e^{-29.14 \cdot \text{SOC}} + 0.04669 \quad (4)$$

$$C_{\text{Transient}_S}(\text{SOC}) = -752.9 \cdot e^{-13.51 \cdot \text{SOC}} + 703.6 \quad (5)$$

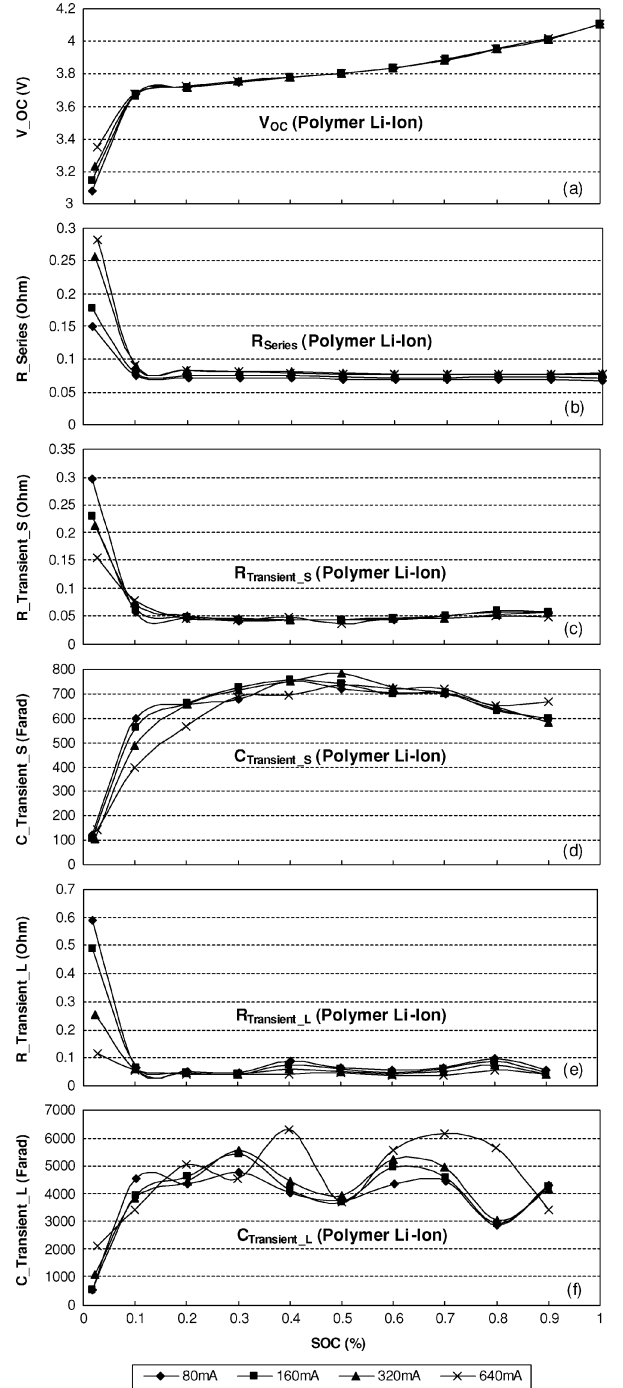

Fig. 7. Extracted parameters of the polymer Li-ion battery at room temperature.

$$R_{\text{Transient}_L}(\text{SOC}) = 6.603 \cdot e^{-155.2 \cdot \text{SOC}} + 0.04984 \quad (6)$$

$$C_{\text{Transient}_L}(\text{SOC}) = -6056 \cdot e^{-27.12 \cdot \text{SOC}} + 4475. \quad (7)$$

To verify the accuracy of extraction results, these parameters were applied to the proposed model in a Cadence environment to simulate the battery voltage response for the same pulse discharge currents that were used for parameter extraction. Table II lists the errors of voltage and runtime for each

TABLE II
MODEL EXTRACTION ACCURACY (POLYMER LI-ION BATTERY)

Pulse Discharge Current (mA)	Max Error Voltage (mV)	Runtime Error *
80	15	0.039%
160	17	0.118%
320	18	0.020%
640	21	0.029%

* Runtime Error = $[\text{Runtime}(\text{Sim}) - \text{Runtime}(\text{Exp})] / \text{Runtime}(\text{Exp})$

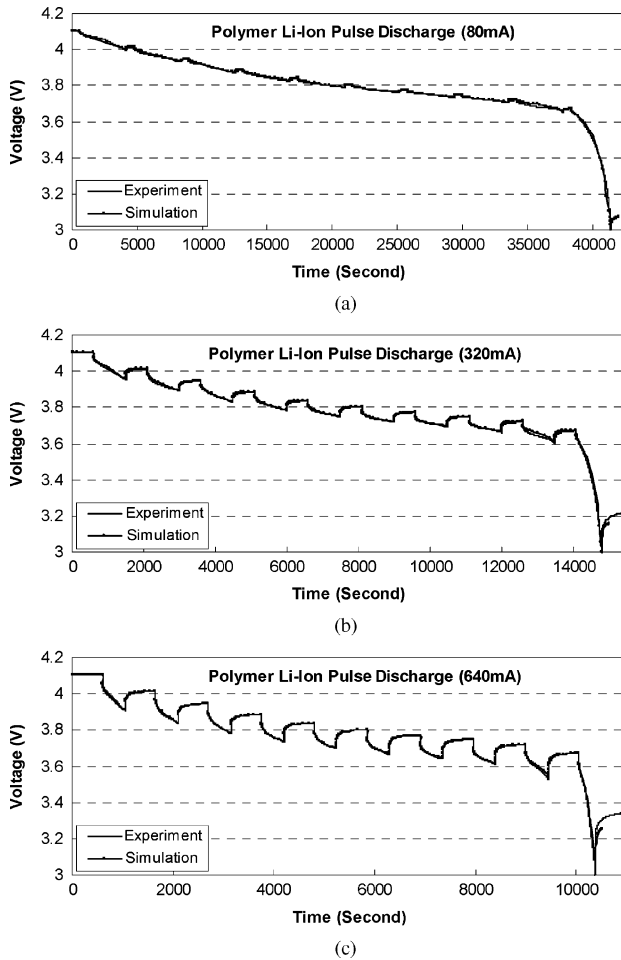

Fig. 8. Comparison between simulation results and experimental data for (a) 80-, (b) 320-, and (c) 640-mA pulse discharge currents for the polymer Li-ion battery.

discharge current, and Fig. 8 shows the simulation results and experimental data of 80-, 320-, and 640-mA discharge currents. The proposed model regenerates voltage response less than 21-mV error and runtime less than 0.12% error of polymer Li-ion batteries accurately. The close agreement manifests the accuracy of the parameter extraction.

VI. MODEL VALIDATION

To validate the extracted model of the polymer Li-ion battery, three different load profiles, i.e., continuous, pulse, and periodic four-step discharges, were applied to the polymer Li-ion battery. The first case is to discharge the polymer Li-ion battery with an 80-mA continuous current. The simulation results

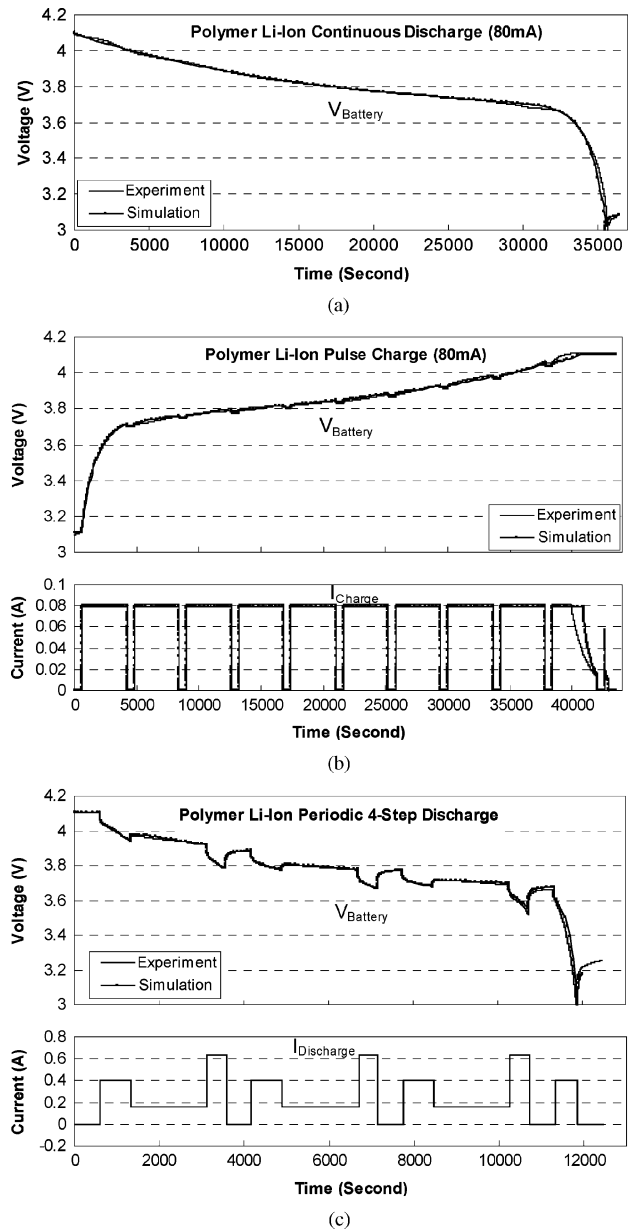

Fig. 9. Comparison between simulation results and experimental data for (a) 80-mA continuous, (b) 80-mA pulse, and (c) periodic four-step discharges for the polymer Li-ion battery.

against experimental data are shown in Fig. 9(a), and they have 15-mV maximum error voltage and 0.395% runtime error. The second case is to pulse charge the polymer Li-ion battery with constant current and then constant voltage (80 mA and 4.1 V). As shown in Fig. 9(b), simulation results match experimental data well, except during the transition period from constant current to constant voltage. The cause of the discrepancy is that the polymer Li-ion battery charge circuit modeled in the Cadence environment has slightly different characteristics with that implemented in the PCB prototype. The last case is to discharge the polymer Li-ion battery with a periodic four-step (0-, 400-, 160-, and 640-mA currents) load profile shown in Fig. 9(c). Similarly, a good match between simulation results and experimental data, 20-mV maximum error voltage and 0.338%

TABLE III
MODEL VALIDATION RESULTS (POLYMER LI-ION BATTERY)

Load Profiles	Max Error Voltage (mV)	Runtime Error (%)
Continuous Discharge	15	0.395%
Pulse Charge	30	0.133%
4-Step Discharge	20	0.338%

runtime error, was reached, indirectly validating the assumptions that the cycle number and self-discharge have negligible effects (Table III).

The close agreement between simulation results and experimental data on NiMH and polymer Li-ion batteries indicates that the proposed electrical battery model predicts runtime and both steady-state and transient voltage responses accurately. At the same time, this model is fully implemented in the Cadence simulator, an industry standard platform, to codesign and cosimulate with other circuits and systems, irrespective of the simulation level, circuit, block, or system level simulation. Furthermore, the proposed model can be extended to other batteries (e.g., lead-acid, NiCd, Li-ion) and power sources (e.g., fuel cells).

VII. CONCLUSION

An accurate, intuitive, and comprehensive electrical model has been proposed to capture the entire dynamic characteristics of a battery, from nonlinear open-circuit voltage, current-, temperature-, cycle number-, and storage time-dependent capacity to transient response. Because of low self-discharge rates, long cycle life, and nearly constant temperature applications (e.g., low power), a simplified model ignoring self-discharge, cycle number, and temperature has been validated by comparing simulation results from Cadence with experimental data on NiMH and polymer Li-ion batteries. The close agreement between simulations and experiments shows that the proposed electrical model accurately predicts battery runtime within 0.4% error and voltage response within 30 mV to any load profile, which is especially important in applications like pacemakers, where exhausted battery energy or circuit malfunction endanger human lives. The model is consistently accurate for over ten polymer Li-ion batteries at 2% runtime variation and 30-mV error voltage at 10%–100% SOC. In all, the proposed model offers circuit and system designers the possibility to improve system efficiency and prolong battery runtime for portable electronics by predicting both operation life and I - V performance accurately, and cosimulating with other circuits in Cadence-compatible simulators, thereby creating a next-generation integral simulation platform bridging the power source to the load application.

APPENDIX

A 750-mAh Duracell HR03 NiMH battery was tested with suitably-spaced pulse discharge currents (75, 100, 150, 300, 500, and 750 mA in this case) at room temperature. Fig. 10 shows the extracted open-circuit voltage

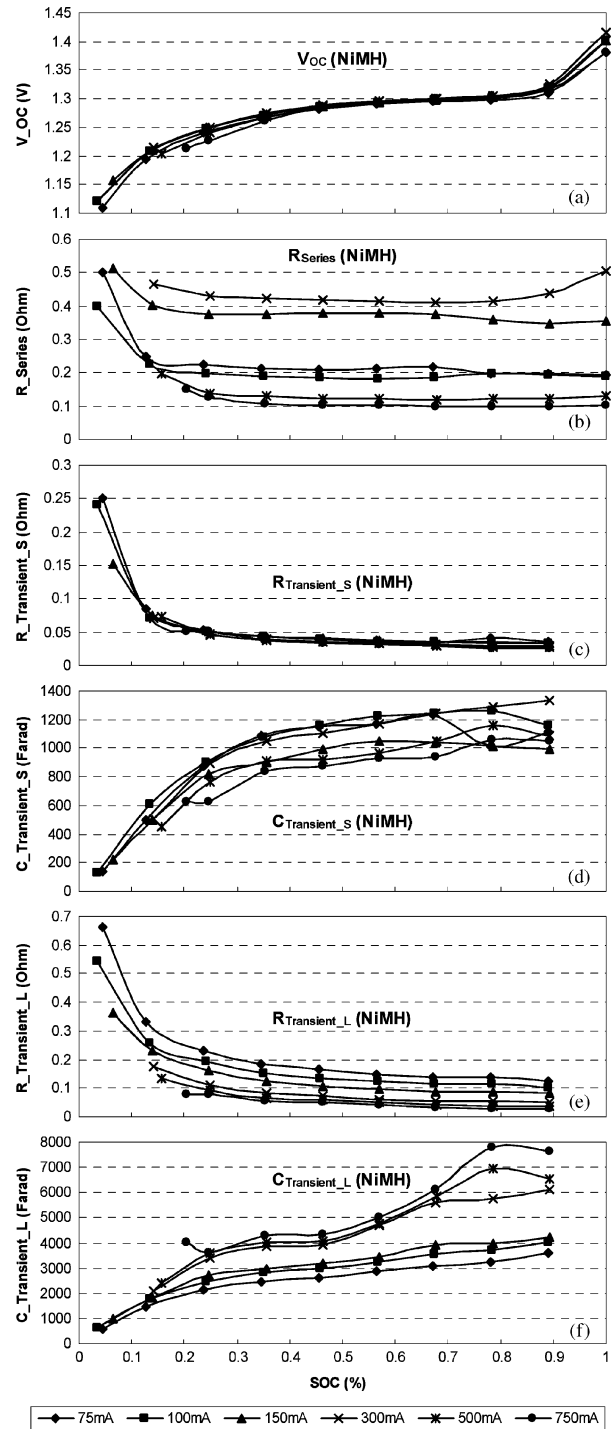

Fig. 10. Extracted parameters of the NiMH battery at room temperature.

V_{OC} , R_{Series} , $R_{Transient_S}$, $C_{Transient_S}$, $R_{Transient_L}$, and $C_{Transient_L}$ as functions of SOC and discharge currents. Unlike polymer Li-ion batteries, most parameters of the NiMH battery strongly depend on current. Therefore, two-dimensional lookup tables with interpolation were created and implemented in the Cadence environment. Table IV lists the errors of voltage and runtime between simulation results and experimental data for various discharge current. The proposed model predicts voltage

TABLE IV
MODEL VALIDATION RESULTS (NiMH BATTERY)

Pulse Discharge Current (mA)	Max Error Voltage (mV)	Runtime Error (%)
75	8	0.008%
100	10	0.122%
150	9	0.209%
300	7	0.083%
500	12	0.332%
750	15	0.054%

response within 15 mV of accuracy and runtime within a 0.34% margin.

REFERENCES

- [1] D. Linden and T. B. Reddy, *Handbook of Batteries*, McGraw-Hill, 3rd ed. New York: McGraw-Hill, 2002.
- [2] L. C. Brush, "Portable devices emerging power solutions," *EDN Power Supplement*, pp. 23–26, Nov. 2003.
- [3] E. Y. Chu, "New challenges for rechargeable batteries," *EDN Power Supplement*, pp. 13–20, Sep. 2002.
- [4] L. Benini, G. Castelli, A. Macci, E. Macci, M. Poncino, and R. Scarsi, "Discrete-time battery models for system-level low-power design," *IEEE Trans. VLSI Syst.*, vol. 9, no. 5, pp. 630–640, Oct. 2001.
- [5] R. Rao, S. Vrudhula, and D. N. Rakhmatov, "Battery modeling for energy-aware system design," *Computer*, vol. 36, no. 12, pp. 77–87, Dec. 2003.
- [6] H. L. Chan and D. Sutanto, "A new battery model for use with battery energy storage systems and electric vehicles power systems," in *Proc. IEEE PES Winter Meeting*, vol. 1, Jan. 23–27, 2000, pp. 470–475.
- [7] C. J. Zhan, X. G. Wu, V. K. Ramachandramurthy, M. Barnes, N. Jenkins, and A. J. Ruddell, "Two electrical models of the lead-acid battery used in a dynamic voltage restorer," in *IEE Proc. Generation, Transmission, and Distribution*, vol. 150, no. 2, Mar., pp. 175–182, 200.
- [8] M. Pedram and Q. Wu, "Design considerations for battery-powered electronics," in *Proc. 1999 Des. Autom. Conf.*, pp. 861–866.
- [9] P. H. Chou, C. Park, J. Park, K. Pham, and J. Liu, "B#: A battery emulator and power profiling instrument," in *Proc. Int. Symp. Low Power Design*, 2003, pp. 288–293.
- [10] C. F. Chiasserini and R. R. Rao, "Energy efficient battery management," *IEEE J. Sel. Areas Commun.*, vol. 19, no. 7, pp. 1235–1245, Jul. 2001.
- [11] L. Song and J. W. Evans, "Electrochemical-thermal model of lithium polymer batteries," *J. Electrochem. Soc.*, vol. 147, pp. 2086–2095, 2000.
- [12] P. M. Gomadam, J. W. Weidner, R. A. Dougal, and R. E. White, "Mathematical modeling of lithium-ion and nickel battery systems," *J. Power Sources*, vol. 110, no. 2, pp. 267–274, Aug. 2002.
- [13] D. W. Dennis, V. S. Battaglia, and A. Belanger, "Electrochemical modeling of lithium polymer batteries," *J. Power Source*, vol. 110, no. 2, pp. 310–320, Aug. 2002.
- [14] J. Newman, K. E. Thomas, H. Hafezi, and D. R. Wheeler, "Modeling of lithium-ion batteries," *J. Power Sources*, vol. 119–121, pp. 838–843, Jun. 2003.
- [15] R. Rynkiewicz, "Discharge and charge modeling of lead acid batteries," in *Proc. Appl. Power Electron. Conf. Expo.*, vol. 2, 1999, pp. 707–710.
- [16] D. Rakhmatov, S. Vrudhula, and D. A. Wallach, "A model for battery lifetime analysis for organizing applications on a pocket computer," *IEEE Trans. VLSI Syst.*, vol. 11, no. 6, pp. 1019–1030, Dec. 2003.
- [17] P. Rong and M. Pedram, "An analytical model for predicting the remaining battery capacity of lithium-ion batteries," in *Proc. Design, Automation, and Test in Europe Conf. and Exhibition*, 2003, pp. 1148–1149.
- [18] P. E. Pascoe and A. H. Anbuky, "VRLA battery discharge reserve time estimation," *IEEE Trans. Power Electron.*, vol. 19, no. 6, pp. 1515–1522, Nov. 2004.
- [19] Z. M. Salameh, M. A. Casacca, and W. A. Lynch, "A mathematical model for lead-acid batteries," *IEEE Trans. Energy Convers.*, vol. 7, no. 1, pp. 93–98, Mar. 1992.
- [20] M. Valvo, F. E. Wicks, D. Robertson, and S. Rudin, "Development and application of an improved equivalent circuit model of a lead acid battery," in *Proc. Energy Convers. Eng. Conf.*, vol. 2, Aug. 1996, pp. 1159–1163.
- [21] M. Ceraolo, "New dynamical models of lead-acid batteries," *IEEE Trans. Power Syst.*, vol. 15, no. 4, pp. 1184–1190, Nov. 2000.
- [22] S. Barsali and M. Ceraolo, "Dynamical models of lead-acid batteries: Implementation issues," *IEEE Trans. Energy Convers.*, vol. 17, no. 1, pp. 16–23, Mar. 2002.
- [23] B. Schweighofer, K. M. Raab, and G. Brasseur, "Modeling of high power automotive batteries by the use of an automated test system," *IEEE Trans. Instrum. Meas.*, vol. 52, no. 4, pp. 1087–1091, Aug. 2003.
- [24] L. Gao, S. Liu, and R. A. Dougal, "Dynamic lithium-ion battery model for system simulation," *IEEE Trans. Compon. Packag. Technol.*, vol. 25, no. 3, pp. 495–505, Sep. 2002.
- [25] M. C. Glass, "Battery electrochemical nonlinear/dynamic SPICE model," in *Proc. Energy Convers. Eng. Conf.*, vol. 1, 1996, pp. 292–297.
- [26] S. Buller, M. Thele, R. W. D. Doncker, and E. Karden, "Impedance-based simulation models of supercapacitors and Li-ion batteries for power electronic applications," in *Conf. Rec. 2003 Ind. Appl. Conf.*, vol. 3, p. 159601600.
- [27] P. Baudry, M. Neri, M. Gueguen, and G. Lonchamp, "Electro-thermal modeling of polymer lithium batteries for starting period and pulse power," *J. Power Sources*, vol. 54, no. 2, pp. 393–396, Apr. 1995.
- [28] S. C. Hageman, "Simple pspice models let you simulate common battery types," *EDN*, pp. 17–132, Oct. 1993.
- [29] S. Gold, "A pspice macromodel for lithium-ion batteries," in *Proc. 12th Annu. Battery Conf. Applications and Advances*, 1997, pp. 215–222.
- [30] S. Abu-Sharkh and D. Doerffel, "Rapid test and non-linear model characterization of solid-state lithium-ion batteries," *J. Power Sources*, vol. 130, pp. 266–274, 2004.

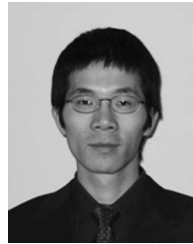

Min Chen (S'04) was born in Jingdezhen, China. He received the B.Eng. degree (with highest honors) and the M.Eng. degree in electrical engineering from Southeast University, Nanjing, China, in 1999 and 2002, respectively. He is currently pursuing the Ph.D. degree in electrical and computer engineering at the Georgia Institute of Technology, Atlanta.

His research interests are in the area of analog and power IC design, more specifically, battery and fuel cell modeling, high-efficiency charger IC design, and integrated power management for hybrid

power sources.



Gabriel A. Rincón-Mora (S'91–M'97–SM'01) was born in Caracas, Venezuela. He received the B.S. degree (high honors) from the Florida International University, Miami, and the M.S.E.E. and Ph.D. degrees from the Georgia Institute of Technology (Georgia Tech.), Atlanta, in 1992, 1994, and 1996, respectively, all in electrical engineering.

From 1994 to 2001, he worked for Texas Instruments, as a Senior Integrated Circuits Designer, Design Team Leader, and Member of Group Technical Staff. In 1999, he was appointed as an Adjunct Professor at Georgia Tech., where he became a full-time faculty member of the School of Electrical and Computer Engineering in 2001. He has authored *Voltage References—From Diodes to Precision High-Order Bandgap Circuits* (New York, Wiley IEEE Press, 2001) and various conference/journal publications. He is the holder of 22 patents in the field of analog and power integrated circuits. His work focuses on integration (power passives, control circuitry, batteries, and energy-harvesting sources), high performance, and power efficiency of solid-state devices, circuits, and systems in various flavors of Bipolar, CMOS, and BiCMOS process technologies.

Dr. Rincón-Mora was the Director of the Georgia Tech. Analog Consortium. He was the Vice-Chairman for the Atlanta IEEE Solid-State Circuits Society-Circuits and Systems (SSCS-CAS) Chapter for 2004 and is now the Chairman. He was the recipient of the National Hispanic in Technology Award from the Society of Professional Hispanic Engineers; the Charles E. Perry Visionary Award from the Florida International University; a Commendation Certificate from the Lieutenant Governor of California for his work and contributions to the field. He was inducted into the "Council of Outstanding Young Engineering Alumni" by Georgia Tech. and featured the cover of Hispanic Business Magazine as one of "The 100 Most Influential Hispanics" and La Fuente (Dallas Morning News publication), and Nuevo Impacto (Atlanta-based magazine). He is a Member of Tau Beta Pi, Eta Kappa Nu, Phi Kappa Phi, and the Society of Hispanic Professional Engineers.